

# LOGICA 05

**Numerically controlled pad printing machine for multicolour printing**

**Up to 5 movement axis easily programming**

**Up to 2 colours dia. 160 mm or 4 colours dia. 130 mm or 5 colours dia. 90 mm**

**Fully electrical operation**

## CHARACTERISTICS

- All the mechanical movements are motorized via numerical control, guarantee high precision providing complete flexibility of operation and simplicity without compromise.
- Its exclusive electric operation presents a considerable advantage compared to an equivalent pneumatic machine.
- Manufactured from light alloy and special steel.
- Eco-friendly. Due to its available hermetic ink system preventing solvent evaporation.
- Independent adjustment of speeds to each of the six strokes, ability to memorize the different and most important phases of the printing cycle.
- Changeover time reduced to a few minutes, thanks to the considerations given in the design concept to apply ergonomic principles to the system.
- Due to the mechanical design quality, a guaranteed smooth working function results in an extremely quiet action, thus allowing use in any environment.
- Ability to print under the printing plate, allowing decoration in every position on the large sized objects.
- The manufacturing was also conceived to guarantee a long life of working without maintenance.
- All adjustment functions can be carried out via the numeric keyboard with alphanumeric display.
- Countdown function and memory of all different work programs for easy set up.
- Ability to print on different surface levels of the same object, adjusting easily the stroke through the keyboard.



Logica 05 4 colours (dia. 130 mm)  
with cross table Mod. TO 100  
on indexer Mod PS 460  
and pad pre-drying devices

## DATI TECNICI

- |  |  |
|--|--|
| • Operation:<br><b>electric with numerical control</b>           | • Standard ink cup sizes:<br><b>up to 2 dia. 160 mm, or 4 dia. 130 mm, or 5 dia. 90 mm</b> |
| • Printing force:<br><b>3000 N</b>                               | • Vertical stroke:<br><b>120 mm (60 mm on cliché)</b>                                      |
| • Maximum printing speed:<br><b>adjustable up to 2100 c/h(*)</b> | • Maximum pad height:<br><b>190 mm (150 mm with pad shuttle system)</b>                    |
| • Number of colours:<br><b>1 - 2 - 3 - 4 - 5</b>                 | • AC supply:<br><b>220/240 V - single phase - 50/60 Hz</b>                                 |
| • Maximum dia. ink cup:<br><b>160 mm</b>                         | • Average consumption and weight (basic model):<br><b>about 1300 W - about 230 Kg</b>      |

(\*) The above mentioned printing speed is the max achievable and will reduce when the vertical pad stroke is increased or when delay times have been programmed into the cycle. The maximum printing speed also depends on the parts loading device.

# LOGICA 05

## SERIE LOGICA FLEXIBLE

### STANDARD COMBINATIONS

To make the choice easier, TOSH proposes a series of standard packages, between the machine and the conveying system, that suits your specific application. Among the suggested and more popular, there are:

- **Cross tables** in different dimensions
- Electromechanical numerically controlled **rotary tables**
- **Pad shuttle systems**, fully electric operation
- Numerically controlled **indexers** with programmable and adjustable pitch
- **Oval flat conveyors** with programmable pitch and nr. of fixtures
- Numerically controlled **doctoring refresher devices**
- **Automatic pad cleaning devices** with programmable operating time
- **Pre-treatment devices** (flame or corona treatment)
- **Drying devices** (air, U.V. and I.R.)
- Modular **pad pre-drying devices**.

#### On the cover a standard combination example of:

Logica 05 equipped to print 4 colours with hermetic cups dia. 130 mm, with cross table Mod. TO 100 on indexer Mod. PS 460

### SIZE BASIC MODEL

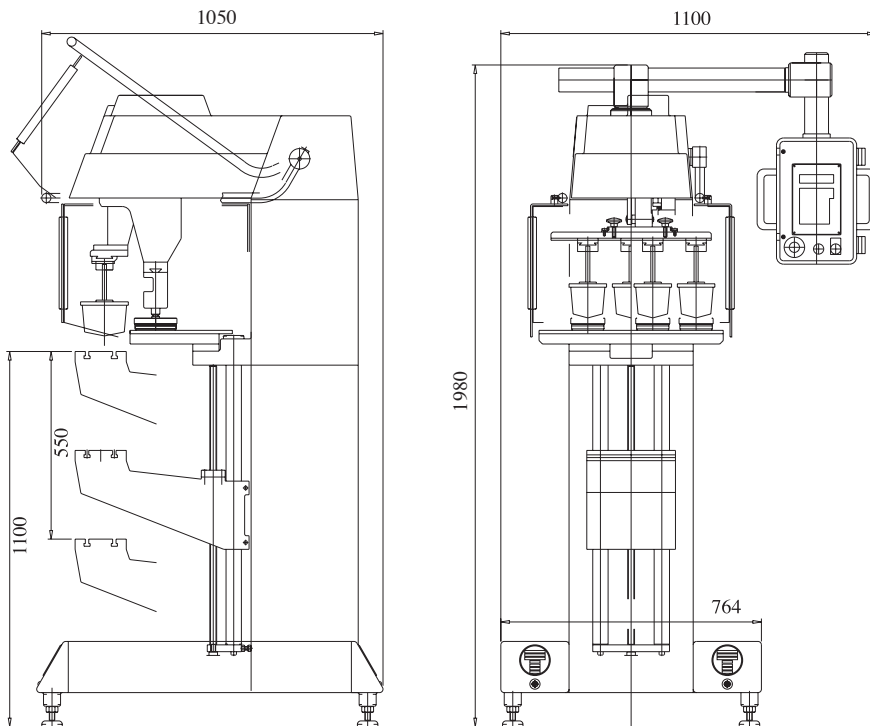

### OPTIONAL

#### Cross tables



Recommended for applications where there is a single fixture, they allow rapid alignment on more axis of the part to the print.

#### Pad shuttle systems



Suggested for 2 or 3 colour printing on a motionless support fixture, ideal also for printing onto cylindrical surfaces.

#### Indexers



Single fixture linear transfers for multicolour printing on medium and large products.

#### Oval flat conveyors



Multifixture linear transfers for multicolour printing on small and medium products or used for additional in-line processes

#### Rotary tables



Recommended for multicolour printing or when high production cadences are required. They can also be used for additional in-line processes.

#### Doctoring refresher devices



Ideal for printing large images that don't fit into ink cup size.

#### Automatic pad cleaning devices



They permit the pads cleaning cycle with programmable operating time.